

TRELLEBORG

I N D U S T R I A L W H E E L S

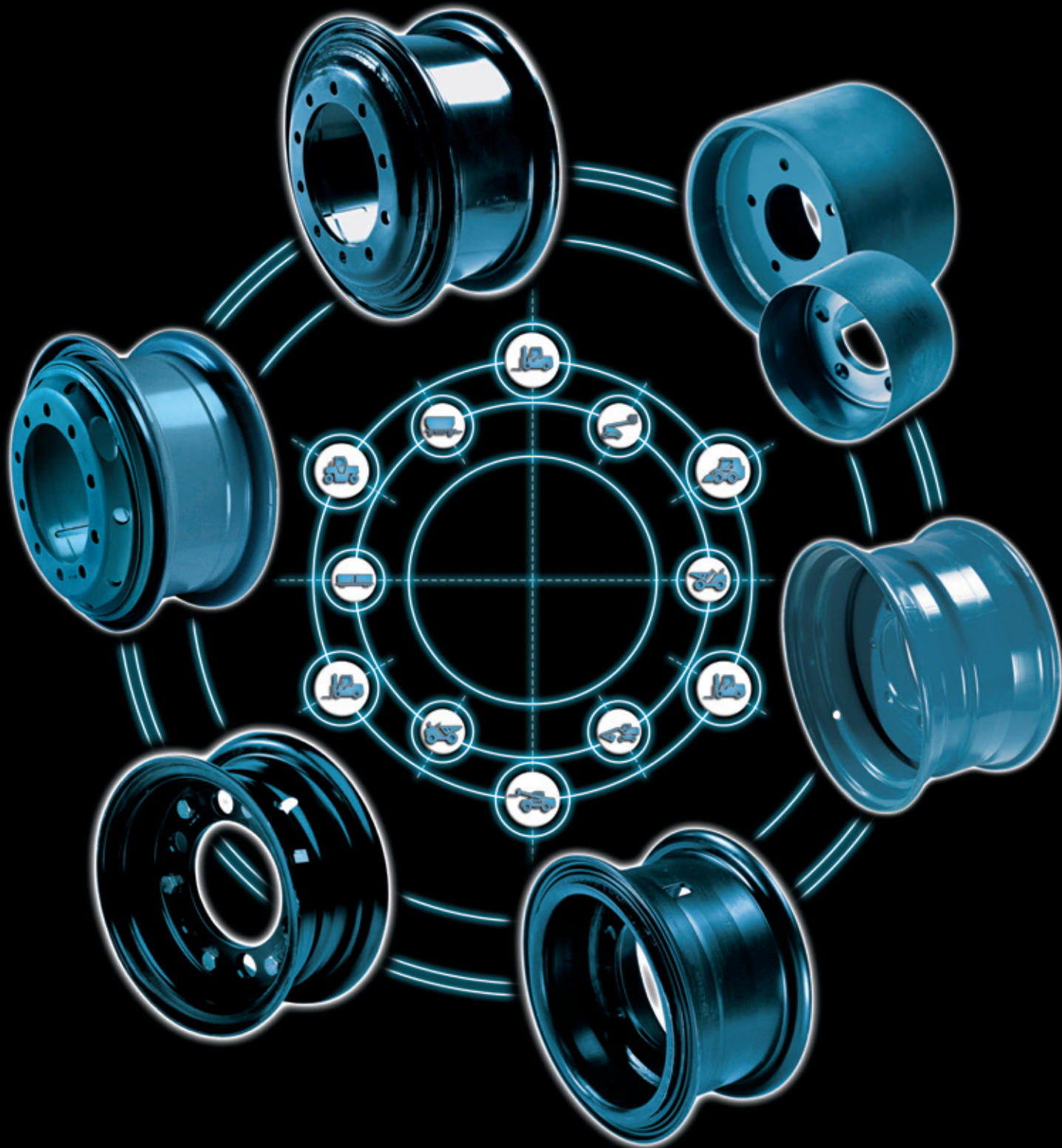

TOTAL SOLUTIONS

TRELLEBORG
WHEEL SYSTEMS

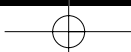
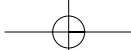

CONTENTS

TRELLEBORG	4
RANGE	5
TECHNICAL FEATURES AND DIMENSIONS	6
GENERAL AND SAFETY RECOMMENDATIONS	7
SPLIT WHEELS	8 - 9
LOCK RING WHEELS	10 - 11
TRELLEBORG 4-PIECE LOCK RING WHEELS (8 TO 15 INCH)	12 - 13
TRELLEBORG 4-PIECE LOCK RING WHEELS (20 & 24 INCH)	14
TRELLEBORG 3-PIECE LOCK RING WHEELS	15
TRELLEBORG SKID-STEER WHEELS - TRELLEBORG EARTHMOVING WHEELS	16
TRELLEBORG POS WHEELS	17
TRELLEBORG WHEELS: SPECIAL REQUIREMENTS	18
SPECIAL ORDER FORM	19

TRELLEBORG

FROM US ... TO YOU ...



Trelleborg® is a leading manufacturer and supplier of high quality wheel systems for industrial applications, such as material handling equipment, trailers, personnel carriers, ground support equipment, aerial lifts, construction equipment and much more. A Trelleborg wheel system is an assembly of tire and wheel designed, engineered and manufactured to perfectly work together, solving all the issues otherwise coming when matching different supplier components.

Our PRIORITY is to supply the appropriate wheel for each Trelleborg Tire in order to offer a complete service to our customers. The top-quality level of our offer is the

result of long term expertise, day-by-day commitment and market knowledge.

We offer robust products, compliant with international standards and with even more tough OEM specific requirements, and easy-mounting solutions.

PARTNERSHIP: YOUR SUCCESS IS OUR SUCCESS

By working closely together with our customers from the stage of product development up to finished product, we are able to tailor our product portfolio to meet customer demands and needs.

SPECIAL PRODUCTS

This catalogue presents our standard industrial wheel range, but if you cannot find the item you are looking for we also offer tailor-made solutions. We are able to produce on order products according to any specific requirements: optional offset, number of holes and even the colour!!

CONSULTING CENTER

If you want to know which wheel suits to your equipment, contact our customer service for consultancy and help. Thanks to our complete application database you will receive the information you need.

TRELLEBORG RANGE

Trelleborg® provides a wide range of industrial wheels that can be fitted with **Resilient, Pneumatic** and **Press-on Solid tires**. All Trelleborg wheels are manufactured in accordance with **E.T.R.T.O.** (European Tire and Rim Technical Organization) standards and by virtue of their quality fulfill all customer's requirements concerning safety and performance. The steel used to manufacture our wheels is of the highest quality, with perfect combination of workability and strenght.

In our range you can find a wheel for each Trelleborg tire.

OUR RANGE INCLUDES:

- **SPLIT WHEELS**
- **LOCK RING WHEELS**
 - 4-PCE: 8"-15"/20" & 24"
 - 3-PCE: 20"
- **EARTHMOVER WHEELS**
- **POS WHEELS**
- **SKID STEER WHEELS**



SPLIT



LOCK RING 4-PCE



LOCK RING 3-PCE



EARTHMOVER



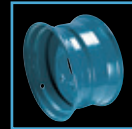

POS



SKID STEER

WHEEL APPLICATIONS

WHEEL TIRE		SPLIT WHEELS	LOCK RING WHEELS 4-PCE	LOCK RING WHEELS 3-PCE	POS WHEELS	SKID STEER WHEELS	EARTHMOVER WHEELS
		RESILIENT	STD	RECOMMENDED	RECOMMENDED	NOT RECOMMENDED	
	LOC/PLUS		RECOMMENDED	NOT RECOMMENDED			
PNEUMATIC	TUBE	RECOMMENDED	RECOMMENDED	RECOMMENDED			
	TUBELESS						RECOMMENDED
	POS				RECOMMENDED		
	SKID STEER					RECOMMENDED	

 = RECOMMENDED
 = NOT RECOMMENDED

TRELLEBORG

TECHNICAL FEATURES AND DIMENSIONS

A wheel is usually composed of a RIM with one or more RINGS and a DISC.

The RIM provides the seat to the tire and its shape can vary in order to optimize the assembly performance and mounting operations. The RIM can have a flat or tapered surface or a drop. The latter are not suitable for solids.

The DISC is the interface between the rim and the axle's hub of our equipment; normally the wheel is bolted to the hub with a number of bolts varying according to specific design of equipment manufacturer.

The RINGS are designed to block the tire in its position on the wheel; the number of rings can vary according to the type of wheel (2-piece, 3-piece or 4-piece wheels). Use always rings from the same manufacturer. Not all Industrial Wheels require rings to perform tire fitment.

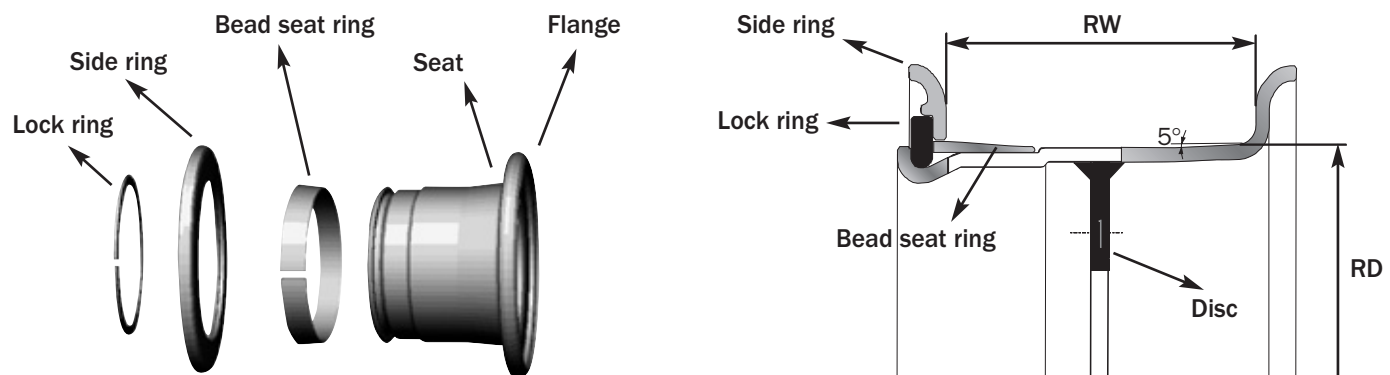

GLOSSARY

SEAT: part of the rim profile that secures the radial fixation of the tire

BEAD SEAT RING: removable ring with the same function as the SEAT

FLANGE: part of the rim profile that secures the axial fixation of the tire

SIDE RING: removable ring with the same function as the FLANGE

LOCK RING: removable ring that secures the good position of the rings

PITCH CIRCLE: fictive diameter on which the centers of the stud holes are located

CENTRAL BORE: or CENTRE HOLE, diameter in the disc (can also be used as centering system for the wheel on the axle hub)

CHAMFER or COUNTERSINK: centres the wheel on the hub

OFFSET: the distance from the attachment face of the central disc to the center line of the rim, it can be positive or negative:

- Positive: when both the rim center line and the hub are inwards with respect to the attachment face
- Negative: when the attachment face is positioned between the rim center line and the hub

Attention! The material thickness is not specified. The standards recommend to consult manufacturer with regard to the appropriate material strength for the intended use. The rim must have sufficient strength, not only to carry the load but also to withstand sudden impacts when hitting curbs, steel rails or when driving on uneven floors.

GENERAL AND SAFETY RECOMMENDATIONS

Wheels are a highly stressed component of the vehicle; for this reason it is necessary to read and follow the information and safety instructions contained in this catalogue. Wheels are a vital safety part of your vehicle, therefore always ensure there is proper treatment and maintenance.

MOUNTING

- The correspondence between wheel and ring is necessary for safety, so, preliminary to mounting, always check rim and tire size carefully: verify if the wheel suits to the selected tire.
- You always need to use rings and wheels of the same manufacturer.
- Always use the correct components to fasten the wheel on the axle.
- Always use the right dimension and type of stud holes.
- Check that nuts are torqued to the correct setting.
- If using tubeless tires, the rim has to be perfectly clean to provide airtightness.
- The mounting and removal of split and multi-piece wheels should only be managed by trained personnel.
- It's better to cross fix the wheel studs and nuts when fitting the wheel to the axle hub, to ensure a better alignment.
- Never use force to place or remove components.
- The correct fitment and positioning of the components of multi pieces wheels has to be checked prior to inflation or deflation; in case of incorrect fitment, demount all the components and restart the mounting procedure.
- The tire must be fully deflated before removing the wheel.

USE AND MAINTENANCE

- References to load carrying capacities and maximum speed limits are to be strictly respected! Tire and wheel load carrying capacity are not the same value, the indication of the tire size mentioned on the catalogues relates only to the possibility to mount the rim on the tire. The wheel load capacity that has to be taken into consideration is the one indicated directly by Trelleborg in accordance with E.T.R.T.O. standards.
- Overstress in use, as well as wrong inflation pressure of pneumatics may results in negative effects on tires and wheels and may lead to the breaking of wheel disc, rim or side ring.
- Choose only neutral and non aggressive mounting pastes to lubricate the tire bead.
- Check periodically the rim area near to the valve hole and the disc area: replace the wheel if there are straining cracks or corrosion marks.
- Clean and paint any paint scratch or oxidation area.
- Always replace damaged wheels. Deformed or damaged wheels should be scrapped! Don't mount any deformed ring. Assembly of wornout, rusty or warped rims and wheels with ovalized stud holes is dangerous and should be omitted.
- Cracked rims or discs must NEVER be re-welded in any circumstances.
- Replace nuts or screws with oxidation traces or that cannot be screwed. Never try to grease them!

TRELLEBORG SPLIT WHEELS

8 TO 12 INCH

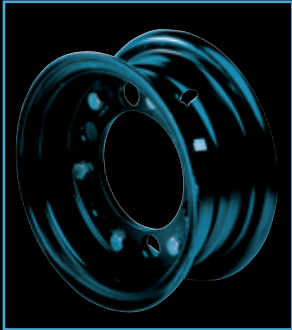

THE EASY FITTING COST SAVING SOLUTION

- RANGE: 8" UP TO 12"
- CONSISTING OF 2 PARTS BOLTED TOGETHER
- SUITABLE FOR RESILIENT (NOT LOC/PLUS VERSIONS) AND TUBE TYPE PNEUMATIC TIRES
- EASY MOUNTING AND ASSEMBLY
- SPECIAL BOLTS FOR ENHANCED SECURITY
- COST EFFECTIVE AND RELIABLE SOLUTION
- SUITABLE FOR SMALL AND MEDIUM INDUSTRIAL TRAILERS AND FORKLIFT TRUCKS, GROUND SUPPORT EQUIPMENT, BAGAGGE CARTS, ETC.

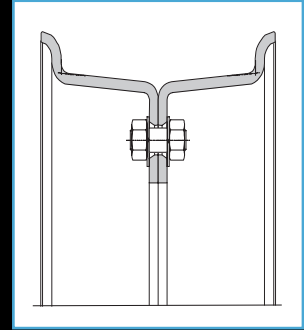

	Rim Size (mm)	Central Bore A (mm)	Pitch circle Ø B (mm)	Number	Ø Hole D (mm)	Ø Chamfer E (mm)	Chamfer type	Trelleborg Partnumber
8 "	3.00 - 8	80	115	5	14,5	19,0	C60	IW11114021
		94	140	5	18,5	24,0	R14	IW11114723
		100	125	6	16,0	19,0	C60	IW11110121
		110	148	6	14,5	17,5	C60	IW11110221
	3.75I - 8	85,7	114,3	5	14,5	17,5	C60	IW11140623
	4.33R - 8	94	140	5	18,5	24,0	R14	IW11162021
9 "	4.00 - 9	130	160	8	16,0	20,0	C60	IW11230121
		140	170	6	16,0	21,0	C60	IW11230921
		142	170	8	17,5	20,8	C60	IW11230221
		150	180	6	17,5	21,0	C60	IW11232021
10 "	5.00 - 10	130	160	8	16,0	20,0	C60	IW11320121
		140	170	6	16,0	20,0	C60	IW11320821
		142	170	8	17,5	20,8	C60	IW11320221
		150	180	6	17,5	21,0	C60	IW11320321
12 "	5.00 - 12	144	190	8	27,0	32,0	C80	IW11450121
		150	200	6	27,0	31,5	C60	IW11450221
		170	220	6	27,0	31,5	C60	IW11450321
		170	220	6	32,0	37,0	R22	IW11450421
		175	220	5	27,0	31,5	C60	IW11450521

*BOLTS, NUTS AND WASHERS INCLUDED

TRELLEBORG

LOCK RING WHEELS

A lock ring wheel features removable circular type locking elements. The wheel is composed of two parts:

- The rim with or without locking elements (bead seat ring, side ring and lock ring)
- The central disc

THE LOCKING RINGS

To secure the tire on the rim, various locking systems are in use

4-PIECE LOCK RING WHEEL

RIM + BEAD SEAT RING + LOCK RING + SIDE RING

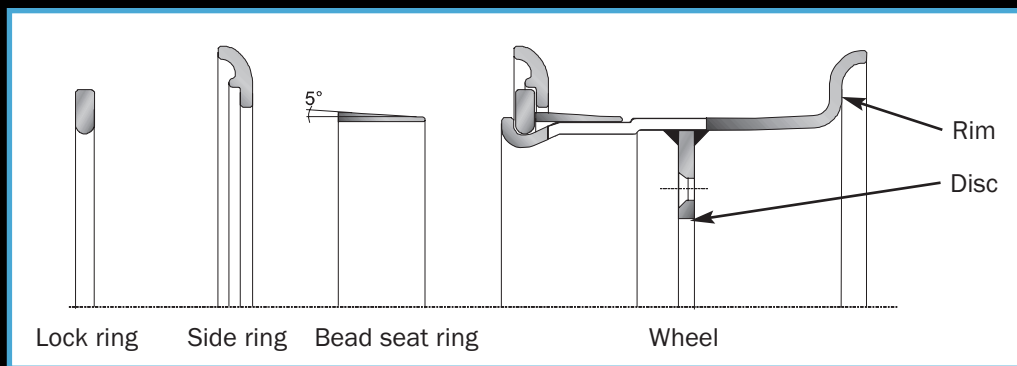

3-PIECE LOCK RING WHEEL

RIM + LOCK RING + COMBI RING (not recommended for resilient tires)

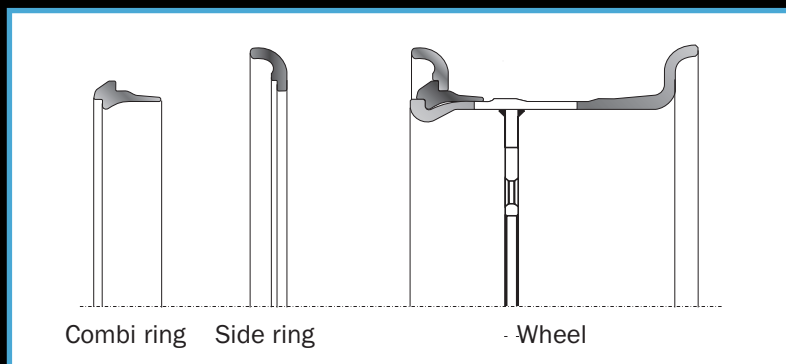

RESILIENT LOC TIRE

The special design of the base makes the locking rings redundant: the tire base is constructed to fit in the gutter of the wheel and assure the axial positioning of it. Trelleborg LOC/PLUS resilient tires fit on the RIM of a 4-piece lock ring wheel without rings.

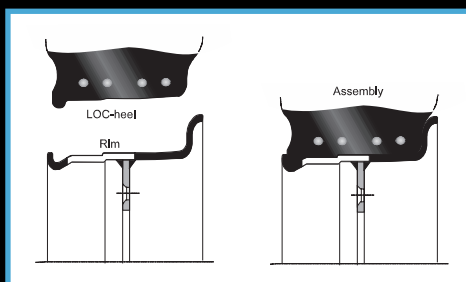

CHARACTERISTICS OF THE CENTRAL DISC

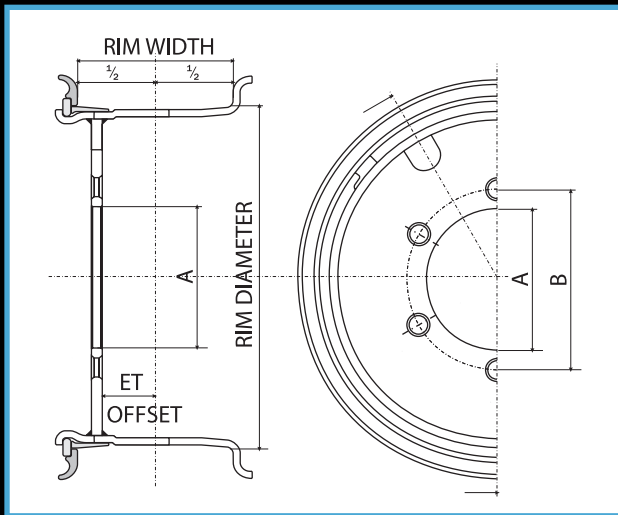

A = centre bore diameter
 B = pitch circle diameter of hub holes
 D = hub hole diameter
 E = chamfer diameter of hub hole

The chamfer can be Conical (C type) or Spherical (R type)

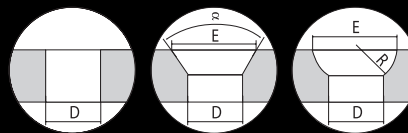

No Chamfer Conical Chamfer Spherical Chamfer

LOCK RING WHEELS DESIGNATION

A lock ring wheel is characterised by three elements:

Example: 5.00 S-12

5.00: rim width (inch)
 S: flange contour
 12: rim diameter (inch)

For resilient tyres, only following contours are appropriate:

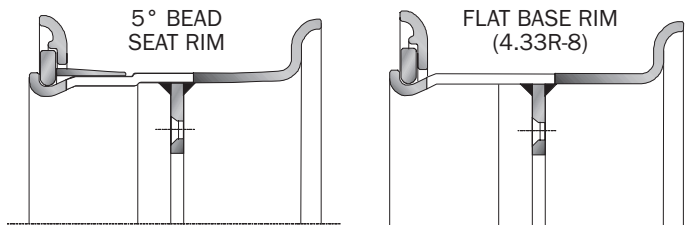

DUAL MOUNTED TIRES

Some items of Trelleborg 4-piece and 3-piece lock ring wheels can be used in a dual configuration.

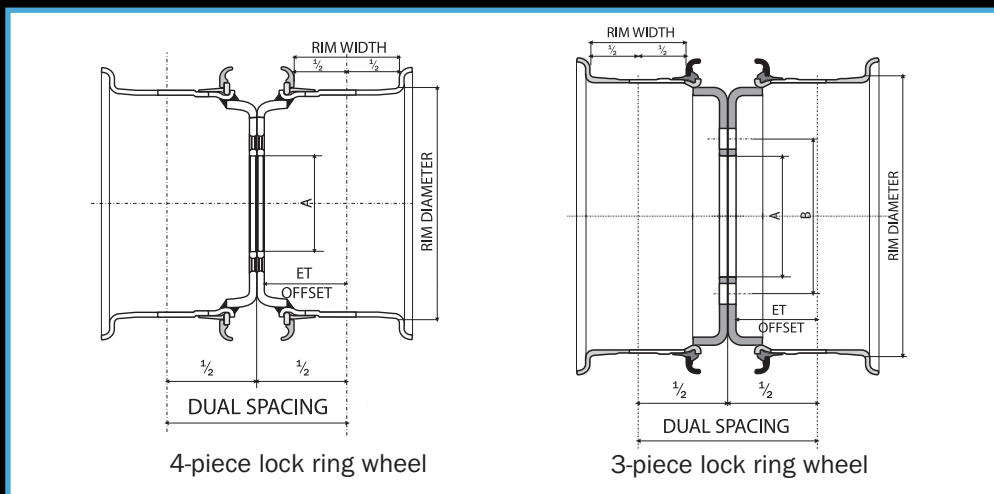

TRELLEBORG

TRELLEBORG 4-PIECE LOCK RING WHEELS

8 TO 15 INCH



THE STRONGEST WHEEL ON EARTH

Our industrial wheels are heavy duty and high air pressure wheels, that can work under the most severe applications.

- RANGE: 8" UP TO 15"
- SUITABLE FOR RESILIENT AND TUBE PNEUMATIC TIRES
- RECOMMENDED FOR LOC AND PLUS VERSIONS OF SOLID TIRES FOR FASTER ASSEMBLY
- SECURE TIRE POSITIONING, LOCKED BY RINGSET
- DUAL MOUNTING SOLUTIONS
- SUITABLE FOR HEAVY DUTY APPLICATION SUCH AS COUNTERBALANCED FORKLIFTS, TRAILERS ETC.

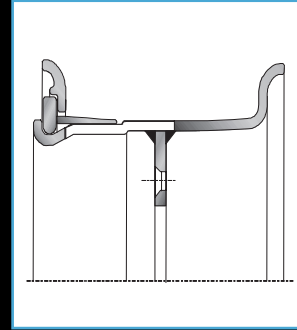

	Rim Size	Central Bore A (mm)	Pitch circle Ø B (mm)	N° of holes	Ø Hole D (mm)	Ø Chamfer E (mm)	Chamfer Type	Offset (mm)	Trelleborg Partnumber	
8"	3.00D-8	100	125	6	16	19	C60	-4,5	IW62 11 21 141	
		100	125	6	16	19	C60	0	IW62 11 21 241	
		101	135	5	14	20	R12	-6	IW62 11 29 141	
		110	145	5	18,5	24	R14	-25,4	IW62 11 03 541	
		110	145	5	18,5	24	R14	-5	IW62 11 03 231	
		110	145	5	18,5	24	2R14	-2	IW62 11 04 141	
		110	145	5	18,5	24	R14	0	IW62 11 03 441	
		110	145	5	18,5	24	R14	35	IW62 11 03 341	
		110	148	6	14,5	18	C60	-4,5	IW62 11 34 141	
		4.33R-8	80	120	5	16	20	C60	20	IW62 16 43 151
			85	130	6	18,5	24	R14	-17	IW62 16 27 241
			90	130	6	17,5	20,8	C60	11	IW62 16 21 241
	100		125	6	16	19,8	C60	-19	IW62 16 37 141	
	100		135	6	17,5	20,8	C60	0	IW62 16 22 141	
	100		135	6	17	21	C60	41	IW62 16 23 141	
	101		135	5	14	20	R12	-7	IW62 16 44 141	
	101		140	6	20	28	R16	-5	IW62 16 32 131	
	110		145	5	18,5	24	2R14	-35	IW62 16 04 541	
	110		145	5	18,5	24	R14	-28	IW62 16 03 341	
	110		145	5	18,5	24	R14	-7	IW62 16 03 841	
	110		145	5	18,5	24	R14	0	IW62 16 03 431	
	110		145	5	18,5	24	R14	14	IW62 16 03 141	
	110		145	5	18,5	24	2R14	25	IW62 16 04 241	
	110		145	5	18,5	24	R14	30	IW62 16 03 541	
	110		145	5	18,5	24	R14	40	IW62 16 03 741	
	110		145	7	18,5	24	R14	0	IW62 16 29 131	
	110		145	7	18,5	24	R14	40	IW62 16 29 341	
	110	148	5	18,5	24	R14	48	IW62 16 30 131		
		125,5	154	10	14			-2	IW62 16 40 141	
	9"	4.00E-9	80	115	4	18,5	24	R14	0	IW62 23 26 141
110			139	6	13,5			-4,5	IW62 23 30 141	
110			160	5	18,5	24	R14	-6	IW62 23 34 141	
123,5			156	6	18,5	24	R14	0	IW62 23 28 131	
123,9			165,1	5	16	22	C90	-11,5	IW62 23 21 241	
130			160	8	16	20	C60	-5	IW62 23 24 141	
140			170	6	18	21	C60	-4,5	IW62 23 29 141	
150			180	6	17,5	20,8	C60	-5	IW62 23 25 141	
6.00E-9			100,1	140	6	18	23	C80	0	IW62 27 29 141
			102,5	142	6	28	32	C80	12	IW62 27 24 141
		110	145	5	18,5	24	R14	4	IW62 27 03 131	
		110	150	6	20	24	C60	64	IW62 27 32 141	
		110	160	5	18,5	24	2R14	24	IW62 27 23 241	
		110	160	5	18,5	24	2R14	74	IW62 27 23 141	
		123,5	156	6	18,5	24	R14	-28	IW62 27 26 131	
		130	160	8	17,5	20,8	C60	-16	IW62 27 25 121	
		140	170	6	17,5	21	C60	-24	IW62 27 31 141	
		150	180	6	17	21	C60	-22	IW62 27 35 141	
10"		5.00F-10	94	140	5	18,5	24	R14	0	IW62 32 31 141
			100	150	6	21,5	27	2R16	34	IW62 32 37 141
	101		139,7	5	18,5	24	R14	-11	IW62 32 22 144	
	110		160	5	18,5	24	R14	0	IW62 32 29 141	
	127		165,1	5	15,5	22,2	C90	-5	IW63 32 26 141	
	130		172	6	21,5	27	R16	0	IW62 32 32 141	
	140		170	6	18	21	C60	-5	IW62 32 25 141	
	144		178	10	18,5	24	R14	-36,5	IW62 32 33 131	
	150		180	6	17,5	20,8	C60	-6	IW62 32 21 220	
	163		195	11	17,5	20,8	C60	-4,5	IW62 32 36 141	
	6.50F-10		85	130	6	18,5	24	R14	-10	IW62 35 28 144
			93	140	10	15			37	IW62 35 30 245
		110	145	5	18,5	24	2R14	-25	IW62 35 04 141	
		110	145	5	18,5	24	R14	7,5	IW62 35 03 541	
		110	145	5	18,5	24	R14	25	IW62 35 03 441	
		110	145	7	18,5	24	R14	-5	IW62 35 29 131	
		110	160	6	21,5	27	R16	54	IW62 35 05 141	
		135	170	6	21,5	27	R16	4	IW62 35 38 141	
		139	170	10	18,5	24	R14	4	IW62 35 27 241	
		145	178	10	18,5	24	R14	10	IW62 35 31 131	
		150	180	8	17,5	20,8	C60	-17,5	IW62 35 36 121	
		161	195	10	18,5	24	R14	-5	IW62 35 21 141	

TRELLEBORG 4-PIECE LOCK RING WHEELS

8 TO 15 INCH

	Rim Size	Central Bore A (mm)	Pitch circle Ø B (mm)	N° of holes	Ø Hole D (mm)	Ø Chamfer E (mm)	Chamfer Type	Offset (mm)	1/2 dual spacing (mm)	Trelleborg Partnumber		
12"	5.00S-12	144	190	8	27	32	C80	-6	110	IW62 45 21 121		
		150	200	6	27	31,5	C60	-6		IW62 45 25 121		
		152	204	5	26			-8		IW62 45 31 121		
		161	205	6	21,5	27	R16	0		IW62 45 06 221		
		161	205	6	21,5	27	R16	30		IW62 45 06 311		
		161	205	6	21,5	27	R16	102		IW62 45 07 121		
		165,7	218	6	32,5	39,5	R22	-6		IW62 45 27 121		
		170	220	6	32,5	39,5	R22	-6		IW62 45 24 121		
		221	250	8	19	25	2R16	-14		IW62 45 28 131		
		93	140	10	15			30		IW62 48 22 141		
		110	160	5	21,5	27	R16	40		IW62 48 05 121		
		140	170	10	18,5	24	R16	10		IW62 48 34 141		
	140	185	6	16			0	IW62 48 36 121				
	144	190	8	27	32	C80	-41	IW62 48 29 321				
	145	178	10	18,5	24	R14	-5	IW62 48 24 221				
	161	205	6	21,5	27	R16	-15	IW62 48 06 321				
	161	205	6	21,5	27	R16	0	IW62 48 06 121				
	161	205	6	21,5	27	R16	30	IW62 48 06 421				
	161	205	6	21,5	27	R16	54	IW62 48 06 241				
	165,7	218	6	32,5	37	R22	-45	IW62 48 33 141				
	170	218	6	16	22	C90	-80	IW62 48 25 141				
	171	220	6	32	37	C60	-40	IW62 48 36 141				
	15"	5.5-15	152,4	203,2	8	16	22	C90	-10	122	IW62 52 22 121	
			202	245	6	26			111		IW62 52 23 111	
		6.0-15	161	205	6	21,5	27	2R16	112	124	IW62 53 07 125	
			176	225	10	27	32	2R18	111		IW62 53 09 113	
		6.5-15	192	270	8	32,2	37	2R22	117	126	IW62 53 22 111	
			161	205	6	21,5	27	R16	0	135	IW62 54 06 121	
161			205	6	21,5	27	R16	124	IW62 54 06 121			
176			225	10	27	32	R18	70	IW62 54 08 111			
176			225	10	27	32	R18	124	IW62 54 08 311			
176			225	10	27	32	2R18	124	IW62 54 09 111			
200			260	6	32,5	37	R22	64	IW62 54 29 111			
202			245	6	26			125	136		IW62 54 34 111	
221			275	8	27	32	2R18	-26			IW62 54 13 713	
221			275	8	27	32	2R18	36	IW62 54 13 813			
221			275	8	27	32	2R18	124	135		IW62 54 24 113	
230			283	12	27	32	R18	38			IW62 54 22 221	
230		283	12	27	32	R18	129	IW62 54 22 111				
240		290	8	32,5	37	2R22	124	135	IW62 54 36 111			
240		290	6	32,5	37	2R22	134		IW62 54 28 111			
7.0-15		161	205	6	21,5	27	2R16	22,5	131	IW62 55 07 313		
		161	205	6	21,5	27	2R16	120		IW62 55 07 213		
		164	222,25	6	32,5	37	R22	40		IW62 55 21 110		
		165,7	218	6	32,5	37	R22	-75		IW62 55 27 111		
		165,7	218	6	32,5	37	R22	-7		IW62 55 27 211		
		170	220	6	32,5	37	R22	-6		IW62 55 25 121		
		176	225	10	27	32	R18	-15		IW62 55 08 321		
		176	225	10	27	32	R18	20		IW62 55 08 621		
		176	225	10	27	32	R18	55		IW62 55 08 111		
		176	225	10	27	32	2R18	75		IW62 55 08 421		
		178	210	14	16			68		IW62 55 29 121		
		190	270	8	27	31,5	C80	78,5		IW62 55 37 151		
		200	250	8	27	35	C60	-13		IW62 55 23 131		
		221	275	8	19	25	2R16	-28,5		IW62 55 32 113		
		221	275	8	21,5	27	2R16	116		128	IW62 55 11 121	
		161	205	6	21,5	27	2R16	120			IW62 56 07 113	
		7.5-15	165	222,5	6	32,5	37	2R22		65	131	IW62 56 22 121
			176	225	10	27	32	2R22		142		IW62 56 09 131
202			245	6	26			-26	155	IW62 56 21 221		
202			245	6	26			15		IW62 56 21 121		
161			205	6	21,5	27	R16	0	IW62 57 06 121			
164,4			222	8	32,5	37,5	2R22	58	IW62 57 24 121			
176			225	10	27	32	R18	-216	IW62 57 08 421			
176			225	10	27	32	2R18	95	IW62 57 09 321			
194			250	6	32,5	37,5	R22	19,5	IW62 57 22 121			
200			260	6	32,5	37,5	R22	56,5	IW62 57 23 121			
221			275	8	27	32	2R18	-40	IW62 57 13 121			
221			275	8	27	32	R18	55	IW62 57 12 121			
9.75-15		230	283	12	27	32	R18	63	IW62 57 14 121			
		161	205	8	21,5	27	2R16	-70	17,5	IW62 58 41 121		
		161	205	6	21,5	27	R16	0		IW62 58 47 121		
		164,4	222,25	6	32,5	37	R22	17,5		IW62 58 33 121		
		165,3	222,2	6	32,2	37	R22	6		IW62 58 45 121		
		165,7	218	6	32,2	37	R22	-45		IW62 58 42 121		
		170	220	6	32	37	C60	-35		IW62 58 48 121		
		176	225	10	27	32	R18	0		IW62 58 08 241		
		176	225	10	27	32	2R18	20		IW62 58 09 143		
		221	275	8	27	32	2R18	-33		IW62 58 13 421		
		221	275	8	27	32	2R18	-13		IW62 58 13 913		
		221	275	8	27	32	R18	12		IW62 58 12 221		
221		275	8	27	32	R18	40	IW62 58 12 521				
221		275	8	27	32	R18	75	IW62 58 12 321				
11.0-15		230	283	12	27	32	R18	63	IW63 58 14 221			
	176	225	10	27	32	R18	0	IW65 59 08 151				
	221	275	8	27	32	2R18	34	IW62 59 13 123				
	230	283	10	27	32	R18	58	IW62 59 14 121				

TRELLEBORG**TRELLEBORG 4-PIECE LOCK RING WHEELS****20 &
24 INCH****THE STRONGEST WHEEL ON EARTH**

Our industrial wheels are heavy duty and high air pressure wheels, that can work under the most severe applications.

- SUITABLE FOR RESILIENT AND TUBE PNEUMATIC TIRES
- SUITABLE FOR HEAVY DUTY APPLICATION SUCH AS COUNTERBALANCED FORKLIFTS, TRAILERS.
- WITHOUT RINGS FOR LOC/PLUS RESILIENT TIRES
- ITEMS SUITABLE FOR DUAL MOUNTED ASSEMBLIES

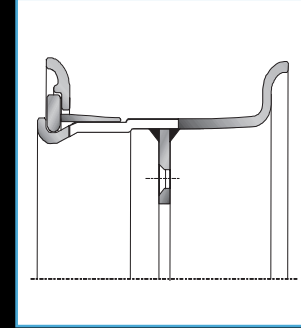

	Rim Size	Central Bore A (mm)	Pitch circle Ø B (mm)	N° of holes	Ø Hole D (mm)	Ø Chamfer E (mm)	Chamfer Type	Offset (mm)	1/2 dual spacing (mm)	Trelleborg Partnumber	
20"	6.5-20	221,6	285,6	10	32,2	37	R22	140	152	IW62 72 32 131	
		161	205	6	21,5	27,5	R16	90		IW62 73 07 131	
	7.5-20	281	335	10	27	R18	32	127	150	IW62 73 22 131	
		281	335	10	26,5			152	165	IW62 74 16 231	
	8.0-20	281	335	10	26	31,5	2C80	169	182	IW62 74 22 131	
			176	225	10	26,0		125	140	IW62 75 21 151	
		281	335	10	26,0			35		IW62 75 16 731	
		281	335	10	26,0			149	162	IW62 75 16 131	
		281	335	10	26,0			167	180	IW62 75 16 431	
		281	335	10	26,0			174	187	IW62 75 16 231	
		281	335	10	27,0	32	2R18	86		IW62 75 17 221	
		281	335	10	27,0	32	2R18	191	203	IW62 75 17 191	
		325	381	12	26,0			174	187	IW62 75 61 231	
		343	400	12	20,0			-20		IW62 75 25 181	
	8.5-20	176	225	10	26			0		IW62 76 25 131	
			281	335	10	25,4	34,4	R18	-11		IW62 76 22 151
		281	335	10	26			158	172	IW62 76 16 151	
		281	335	10	26	28	C90	158	172	IW62 76 16 141	
		281	335	10	26			162	176	IW62 76 16 431	
		281	335	10	26			169	182	IW62 76 22 251	
		281	335	10	26	28	C90	172	187	IW62 76 16 751	
		281	335	10	26			173	188	IW62 76 17 151	
		281	335	10	26			174	189	IW62 76 16 651	
		281	335	10	26			190	205	IW62 76 16 351	
		281	335	10	27	32	2R18	173	188	IW62 76 24 251	
		10.0-20	325	381	12	26			174	189	IW62 76 23 251
	221			275	8	27	32	R18	4		IW62 77 12 221
	230		283	12	27	32	2R18	62		IW62 77 14 251	
			281	335	10	24			-37		IW62 77 30 141
	281		335	10	26			145	159	IW62 77 16 341	
	281		335	10	26			163	178	IW62 77 16 251	
	281		335	10	27	32	2R18	165	180	IW62 77 17 151	
281	335		10	27	32	2R18	199	214	IW62 77 17 251		
284	335		10	26			216	229	IW62 77 21 131		
16.0-20	361		400	16	27	32	R18	0		IW62 79 21 181	
24"	8.5-24	281	335	10	26			158	176	IW62 84 16 281	
		281	335	10	26			182	196	IW62 84 16 251	
		281	335	10	27	32	2R18	172	187	IW62 84 17 251	
	10.0-24	370,9	422,3	12	32,5	37,5	R22,2	10		IW62 84 21 151	
		371	425	12	26			60		IW62 84 18 341	
		371	425	12	26			173	187	IW62 84 18 141	
		371	425	12	26			175	190	IW62 84 18 151	
		371	425	24	26			154	172	IW62 84 18 281	
		371	425	24	26			172	190	IW62 84 22 181	
		11.25-24	281	335	10	25,4	34,4	R18	-64		IW62 86 28 161
			371	425	12	26			175	190	IW62 86 18 151
			371	425	12	26			207	222	IW62 86 18 251
			371	425	12	26			210	225	IW62 86 18 351
			371	425	12	27	32	R18	207	225	IW62 86 19 281
			371	425	24	26			207	225	IW62 86 21 261
	11.25-24	371	425	12	26			200	215	IW62 87 18 171	

TRELLEBORG 3-PIECE LOCK RING WHEELS

20 & 24 INCH

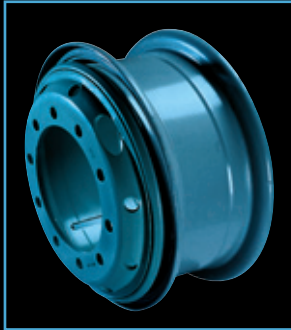

THE CHEAPER SOLUTION FOR ORDINARY APPLICATIONS

- 20" SOLUTIONS (8.5-24 ON REQUEST)
- SUITABLE FOR PNEUMATIC TIRES (TUBE TYPE) ONLY
- COST-SAVING SOLUTION
- SUITABLE FOR MEDIUM DUTY APPLICATIONS LIKE TRAILERS
- ITEMS SUITABLE FOR DUAL MOUNTED ASSEMBLIES

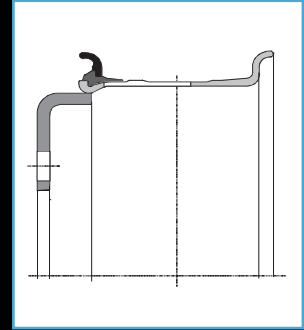

	Rim Size	Central Bore A (mm)	Pitch circle Ø B (mm)	N° of holes	Ø Hole D (mm)	Ø Chamfer E (mm)	Chamfer Type	Offset (mm)	1/2 dual spacing (mm)	Trelleborg Partnumber	
20"	6.0-20	221	275	8	25			162	174	IW65 71 21 121	
		161	205	6	21			85		IW65 72 30 125	
	6.5-20	161	205	6	21			162	174	IW65 72 31 125	
		221	275	8	25			85		IW65 72 21 125	
		221	275	8	25			90		IW65 72 21 325	
		281	335	10	27	32	2R18	134	146	IW65 72 17 121	
	7.0-20	281	335	10	26			149	162	IW65 73 16 131	
	7.5-20	221	275	8	27	32	2R18	156	167	IW65 74 13 218	
		281	335	10	26			149	162	IW65 74 16 131	
	8.0-20	221	275	8	25,4	31,5	R18	-7,5			IW65 75 24 121
		281	335	10	27	32	R18	152	165	IW65 75 28 131	
		281	335	10	26,0	31,5	C80	161	174	IW65 75 22 133	
		281	335	10	26,0			174	187	IW65 75 16 231	
	8.5-20	326	380	10	27,0	32	R18	-161	-161	IW65 75 26 198	
		281	335	10	26			0			IW65 76 16 541
		281	335	10	26	32	2R18	175	188	IW65 76 17 231	
24"	8.5-24	on request									

TRELLEBORG

TRELLEBORG SKID-STEER WHEELS

16.5 TO 19.5 INCH



TOP PERFORMANCE IN HEAVY DUTY APPLICATION

- 1 PIECE WHEEL
- ROBUST DESIGN
- INTERNAL SURFACE WELL FINISHED TO PREVENT TUBE DAMAGING
- SUITABLE FOR SKID STEER MACHINES, ROUGH TERRAIN TELEHANDLERS, MOBILE OFF-ROAD PLATFORMS, ETC.

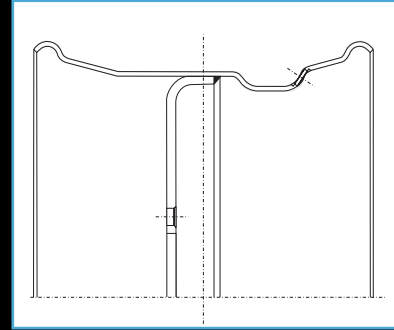

	Rim Size	Central Bore A (mm)	Pitch circle Ø B (mm)	N° of holes	Hole Type	Ø Hole D (mm)	Ø Chamfer E (mm)	Chamfer Type	Offset (mm)	Trelleborg Partnumber
16.5"	8.25x16.5	161	205	6	A2	21,5	27	R16	0	IW68 66 06 121
		117,8	152,4	6		15	20	C90	27	IW68 66 21 121
		152,4	203,2	8		17,5	22	C90	18	IW68 66 22 121
	9.75x16.5	161	205	6	A2	21,5	27	R16	0	IW68 68 06 121
		152,4	203,2	8		17,5	22	C90	33	IW68 68 21 141
		152,4	203,2	8		17,5	22	C90	-22	IW68 68 21 221
		152,4	203,2	8		17,5	22	C90	45	IW68 68 21 321
17.5"	10.5x17.5	161	205	6	A2	21,5	27	R16	0	IW68 77 06 121
19.5"	11.75x19.5	161	205	6	A2	21,5	27	R16	0	IW68 79 06 121

TRELLEBORG EARTHMOVING WHEELS

25 INCH



LOCKING SYSTEM TO PREVENT SLIPPAGE IN HIGH TRACTION APPLICATION

- MADE OF 3 OR 5 PCS.
- FOR EARTHMOVER (TUBELESS) TIRES ONLY
- RELIABLE AND ROBUST SOLUTION
- SUITABLE FOR EARTHMOVING AND CONSTRUCTION EQUIPMENT



	Rim Size	Central Bore A (mm)	Pitch circle Ø B (mm)	N° of holes	Ø Hole D (mm)	Ø Chamfer E (mm)	Chamfer Type	Offset (mm)	Trelleborg Partnumber
25"	11.25-25/2.0	281	335	10	26			40	IW61 87 21 151
		281	335	10	26			145	IW61 87 21 251
		365	425	12	27			5	IW61 87 22 181
		371	425	12	27			90	IW61 87 23 181
		Clampfitting							

TRELLEBORG POS WHEELS

UP TO
40 INCH

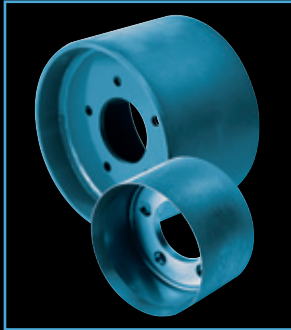

FROM SMALLER TO BIGGER SIZES

- RANGE: UP TO 40"
- FOR CASTED OR WELDED WHEELS
- STRICT TOLERANCES TO ENSURE CORRECT MOUNTING
- FOR HEAVY LOAD APPLICATIONS AND COUNTERBALANCED FORKLIFT AND TRAILERS

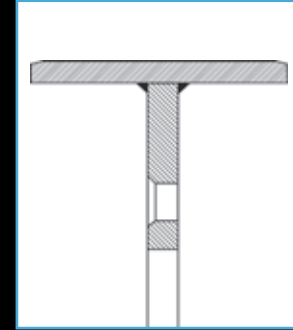

Trelleborg Partnumber	inch	D mm	inch	B mm	Central Bore A (mm)	Pitch circle Ø B (mm)	N°	Ø Hole D (mm)	Ø Chamfer E (mm)	Chamber type	Offset (mm)
IW67 14 22 141	8	203,2		100	105	140	5	15	23	C90	B47
IW67 31 21 151	11 ¹ / ₂	286		148	99	135	5	13	19	C90	B80
IW67 32 21 151	11 ¹ / ₂	286	5	127	115	145	4	18			B60
IW67 32 22 141	10	254	5	127	186	216	5	12	15	C60	A40
IW67 34 21 157	10 ¹ / ₂	267	6	152	110	145	5	21,5	27	16	B69
IW67 36 30 145	10 ¹ / ₂	267	7	178	93	140	5	14	18	C90	A45
IW67 45 21 141	12 ¹ / ₈	308		140	108	136	8	14,5	18,8	C60	B101
IW67 45 24 211		305		130	Bearing						B59
IW67 46 23 111	12 ¹ / ₈	308	6	152	110	145	5	15	23	C90	B106
IW67 57 21 111	15	381	8	203	103	142	6	20	2x60		B93
IW67 67 21 181	16	406		217	160	205	6	21,5	27	R16	B109
IW67 67 22 157	16	406	8	203	145	180	14	16			B174
IW67 79 13 253	22	558,8	14	355,6	221	275	8	27,0	32,0	2R18	B185
IW67 79 13 353		600		320	221	275	8	27,0	32,0	2R18	B140
IW67 79 30 183	22	558,8	12	304,8	151	203,2	8	21,5	23,5	C90	B157,5
IW67 79 31 181	22	558,8	12	304,8	270	305	12	18,0			A144
IW67 99 23 181	30	762	16	406,4	361	400	16				B265

D= RIM DIAMETER
B= RIM WIDTH

OFFSET: A= DISTANCE FROM FRONT TO DISC
B= DISTANCE FROM DISC TO BACK

DIMENSIONAL TOLERANCES

The wheel diameter

for inch-sizes = Nominal Rim Diameter + 0.005 inch
- 0.000 inch

for metric sizes = h6 according to ISO286-2

To facilitate mounting, the wheel must have a bevelling on at least one side.

The width of bevelling is minimum: 3 mm for tire section widths up to 105 mm
5 mm for tire section widths over 105 mm

The angle of the bevel to the axle is 30°.

Attention: No welding or flame cutting on the wheel or central disc is allowed while the tire is mounted: the heat generated would destroy the rubber-metal adhesion.

TRELLEBORG

TRELLEBORG WHEELS SPECIAL REQUIREMENTS



We want to meet our customer requirements and special needs, whatever they may be; therefore we also offer a flexible and tailored production.

All our RIMs and Wheels are compliant to E.T.R.T.O. international standards and manufactured from raw materials of the highest quality.

Our workshop, located in Belgium, is equipped with state-of-the-art machine tools and can produce a large range of wheels, from 8" up to 40", both for heavy industrial and material handling applications.

Experienced and specialized workers take care of product consistency and final inspection of products.

From steel to finishing and painting, we control all production stages, with particular attention to critical operations such as welding. A careful check follows each activity.

All this ensures high quality and short delivery times.

To simplify the ordering process we prepared the following form with all the information we need in order to fulfill your needs.

CONSULTING CENTER

Trelleborg offers a consulting service that helps our customers to know which wheels suits to their industrial equipment.



SPECIAL ORDER FORM

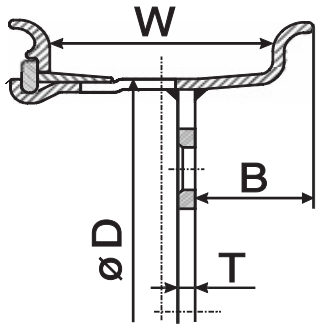

WHEEL SPECIFICATIONS

Company: _____

Wheel size (WxøD): _____ with rings

without rings

Wheel: Manufacturer: _____ Partn°: _____

Tire size: _____ solid tire

pneumatic tire

Vehicle: Brand: _____ Model: _____

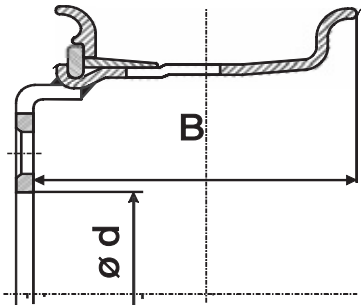

Thickness of the disc T: _____ mm

Centre bore diameter ø d: _____ mm

Position of the disc B: _____ mm (or Offset: ± ____ mm)

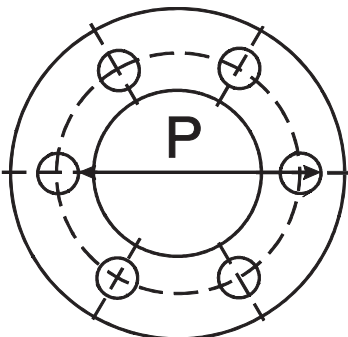

Pitch Circle Diameter :

P: _____ mm or F: _____ mm

Stud holes:

Number of stud holes: _____

Stud hole diameter G: _____ mm

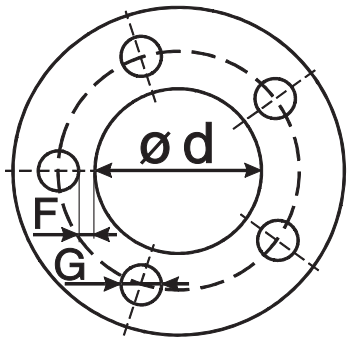

With counter sink:

Counter sink diameter H: _____ mm

Conical a: _____ ° Spherical R: _____ mm

one side

two sides

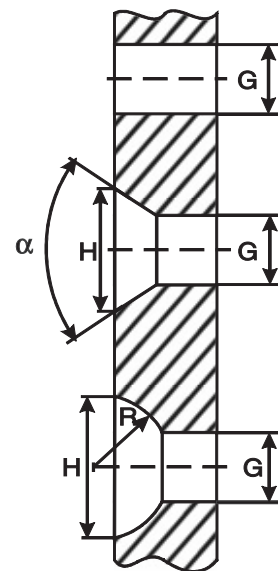

REMARKS : _____

EUROPEAN SALES OFFICES**BELGIUM**

**TRELLEBORG WHEEL SYSTEMS
BELGIUM NV**
HEAD QUARTERS BUSINESS UNIT EUROPE
BRUGSESTEENWEG 7
9940 EVERGEM
TEL: 0032 - 92572211
FAX: 0032 - 92572230
Email: twsb.sales@trellborg.com

GERMANY

**TRELLEBORG WHEEL SYSTEMS
GMBH & CO. KG**
KLEBERSTRASSE 2
D-40822 METTMANN
POB 10 01 52 . D-40805 METTMANN
TEL: 0049 - (0)2104-217-282
FAX: 0049 - (0)2104-217-291

ESPAÑA

**TRELLEBORG WHEEL SYSTEMS
ESPAÑA, S.A.**
VALENCIA, 333, 3° 1°
08009 BARCELONA
TEL: +34 93 208 14 80
FAX: +34 93 458 84 74

GREAT BRITAIN

TRELLEBORG WHEEL SYSTEMS
RESOLUTION ROAD
FLAGSTAFF 42
ASHBY DE LA ZOUCH
LEICESTERSHIRE
LE67 1AA
TEL: 0044 - 1530 - 565656
FAX: 0044 - 1530 - 565600
DIRECT LINE IN UK: 0800 - 328 9660

RUSSIA

**TRELLEBORG
INDUSTRI O.O.O. (LTD)**
ROSHCHINSKIY PROEzd 8.2-oy
RU-117 419 MOSCOW
TEL: 007 - 952325579
FAX: 007 - 952322264

CZECH REPUBLIC

TRELLEBORG CZ S.R.O.
CHLUMCANSKÉHA 10
CZ-180 00 PRAHA 8
TEL: 0042 - 0283842600
FAX: 0042 - 0283841699

POLAND

TRELLEBORG POLSKA SO Z.O.O.
6-8 SZAPARAGOWA STR
PL 91-211 LODZ
TEL: 0048 - 426506868
FAX: 0048 - 426525181

AMERICAN SALES OFFICES**GEORGIA**

4820 Clark Howell Hwy, Unit C East 8
College Park, GA 30349
Tel: 001 4047613708
Fax: 001 4047613085

ILLINOIS

5335 S.WESTERN blvd.
Chicago, IL 60609
Tel: 001 7739259599
Fax: 001 7739259588

TEXAS

4656 Leston Avenue, Suite 518
Dallas, TX 75247
Tel: 001 2146301530
Fax: 001 2146301577

CALIFORNIA

7704 North Avenue
Lemon Grove, CA 91945
Tel: 001 3308771211
Fax: 001 3308772346

NEW YORK

6 Washington Avenue
Fairfield, NJ 07004
Tel: 001 973 8082288
Fax: 001 9738082299

OTHERS SALES OFFICES**AUSTRALIA**

**TRELLEBORG QUEENSLAND
RUBBER CO PTY LTD**
515 ZILLMERE ROAD
PO BOX 84
ZILLEMERE QLD 4034
TEL: 00617 38667444
FAX: 00617 38667471

BRAZIL

TRELLEBORG DO BRASIL LTDA.
RUA CORONEL J. A. MARTINS, 2794
LAGO DE PRATA - CX POSTAL 434
LENCOIS PAULISTA - SP
BR-CEP 18682-050
TEL: 0055-142643609
FAX: 0055-142633713

INDONESIA

PT TRELLEBORG INDONESIA
HOTEL CIPUTRA JAKARTA
JALAN LENAN JENDRAL S PARMAN
SUITE NO 822-823
JAKARTA 11470
TEL: 0062 2156954752
FAX: 0062 2156954751

MALAYSIA

TRELLEBORG MALAYSIA SDN BHD
NO 22 JALAN 30B/146
TAMAN DESA TASI, SUNGAI BESI
MY-57000 KUALA LUMPUR
TEL: 0060 - 390596388
FAX: 0060 - 390593169

THAILAND

TRELLEBORG THAILAND LTD
3539 SOI VISETSUK (5)
NEW RAMA IX RD.
KWANG SAUNLANG
KHET SAUNLANG
TH-102 50 BANGKOK
TEL: 0066 - 27322861-3
FAX: 0066 - 27322864

SINGAPORE

TRELLEBORG S.E.A. PTE LTD
10 TOH GUAN ROAD #03-06
TT INTERNATIONAL TRADEPARK
SG-SINGAPORE 608838
TEL: 0065 - 68989332
FAX: 0065 - 68989303
E-mail: tseapl@singnet.com.sg

SOUTH AFRICA

**TRELLEBORG
SOUTH AFRICA (PTY) LTD**
PO BOX 12459
CORNER NEDERVEEN
HIGHWAY / PHILIPS ROAD
ZA-ELSPARK 1418
TEL: 0027 - 118653110
FAX: 0027 - 118652965

FACTORIES AND DISTRIBUTION**USA**

**TRELLEBORG WHEEL SYSTEMS
AMERICAS INC.**
61 State Route 43 North
Hartville, OH 44632-0430
Tel: 001 3308771211
Fax: 001 3308772346

SRI LANKA

TRELLEBORG LANKA LTD.
Sapugaskande
Makola
Tel: 0094 1521803
Fax: 0094 1549541